

Incremental encoders

Blind hollow shaft $\varnothing 12$ mm

50...1024 pulses per revolution

ITD 20 A 4 Y130



ITD 20 A 4 Y130 with blind hollow shaft

Features

- Encoder with electric isolated blind hollow shaft $\varnothing 12$ mm
- Max. 1024 pulses per revolution
- Optical sensing
- Mounting by electrically isolated torque support
- TTL or HTL output signals
- Flange socket radial
- High protection standard
- Protection against inductive shaft current

Technical data - electrical ratings

Voltage supply	5 VDC ± 5 % 8...30 VDC
Reverse polarity protection	Yes
Consumption w/o load	≤ 100 mA
Pulses per revolution	50...1024
Reference signal	Zero pulse, width 90°
Sensing method	Optical
Output frequency	≤ 120 kHz
Output signals	A, B, N + inverted
Output stage	TTL linedriver (short-circuit proof) HTL push-pull (short-circuit proof)
Interference immunity	DIN EN 61000-6-2
Emitted interference	DIN EN 61000-6-3

Technical data - mechanical design

Size (flange)	$\varnothing 58$ mm
Shaft type	$\varnothing 12$ mm (blind hollow shaft)
Motor shaft tolerance	0.25 mm axial 0.1 mm radial
Mounting kit	044
Protection DIN EN 60529	IP 65
Operating speed	≤ 8000 rpm ≤ 5000 rpm IP 65 ($> 70^\circ\text{C}$)
Starting torque	≤ 0.01 Nm ($+20^\circ\text{C}$)
Materials	Housing: aluminium, black, powder-coated Shaft: stainless steel
Operating temperature	$-20...+70^\circ\text{C}$ $-20...+100^\circ\text{C}$
Relative humidity	90 % non-condensing
Resistance	DIN EN 60068-2-6 Vibration 10 g, 55-2000 Hz DIN EN 60068-2-27 Shock 100 g, 11 ms
Connection	Connector M23 type 2, 12-pin
Weight approx.	280 g

Incremental encoders

Blind hollow shaft $\varnothing 12$ mm

50...1024 pulses per revolution

ITD 20 A 4 Y130

Part number

ITD 20 A 4 Y130 D2SR12 12 IP65 044

Mounting kit

044 Mounting accessory kit 044

Protection

IP65 IP 65

Blind hollow shaft

12 $\varnothing 12$ mm

Operating temperature

S -20...+70 °C

E -20...+100 °C

Connection

D2SR12 Flange socket type 2, pin contacts, radial, 12-pin

Output signals

BI A, A inv, B, B inv

NI A, A inv, B, B inv, 0, 0 inv

Voltage supply / signals

T 5 VDC / TTL level, linedriver

H 8...30 VDC / HTL level, push pull

R 8...30 VDC / TTL level, linedriver

Pulse number - see table

Pulse number

50	90	200	360	600
60	100	250	400	1000
64	120	254	500	1024
88	128	256	512	

Accessories

Connectors and cables

11072792 Connector S2BG12, 1 m cable (ITD)

Incremental encoders

Blind hollow shaft $\varnothing 12$ mm

50...1024 pulses per revolution

ITD 20 A 4 Y130

Output signals

Clockwise rotation when looking at the mounting side.

BI-Output signals

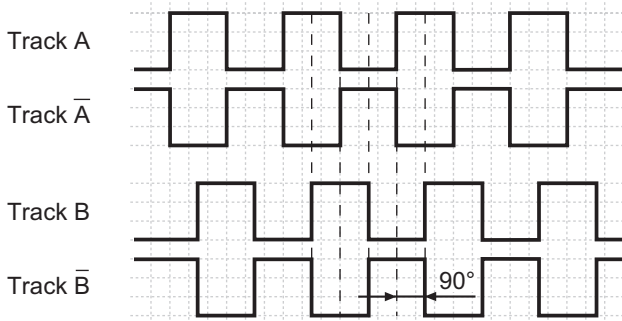

NI-Output signals

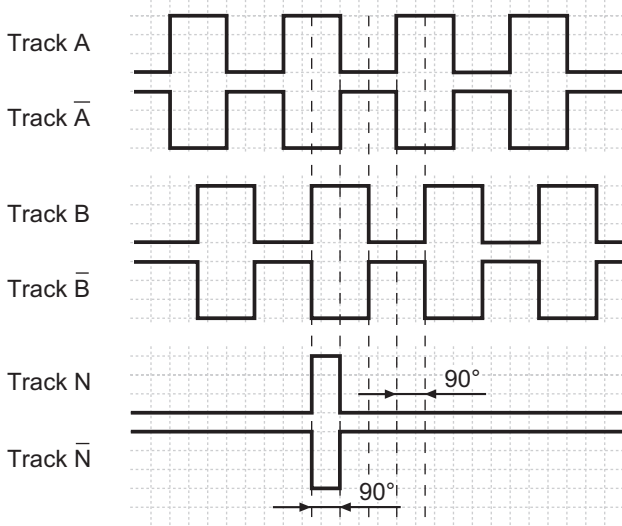

Terminal assignment

Connector	Assignment
Pin 5	Track A
Pin 6	Track A inv.
Pin 8	Track B
Pin 1	Track B inv.
Pin 3	Track N
Pin 4	Track N inv.
Pin 12	UB
Pin 10	GND
Pin 2	UB-Sense
Pin 11	GND-Sense
Pin 9	-
Pin 7	-

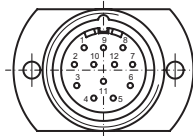

Trigger level

Outputs	Linedriver
Output level High	≥ 2.4 V
Output level Low	≤ 0.5 V
Load	≤ 70 mA

Outputs	Push-pull short-circuit proof
Output level High	$\geq UB - 3$ V
Output level Low	≤ 1.5 V
Load	≤ 70 mA

Dimensions

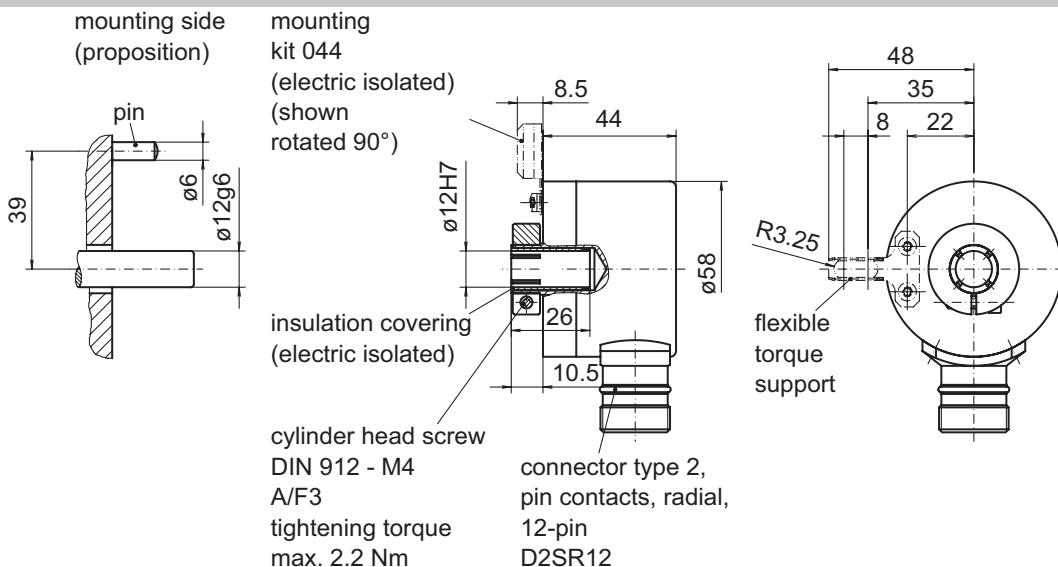

029- 1 Y130

Incremental encoders
Blind hollow shaft $\varnothing 12$ mm
50...1024 pulses per revolution

ITD 20 A 4 Y130